

DIVERSIFIED AIR SYSTEMS, INC.

MAXFLO-HC™

Horizontal downflow pleated cartridge dust collector



- *Designed for welding, buffing and grinding applications, pharmaceutical and food plants, bulk and powder processes*
- *Modular for various air volume capacities*

- *Automatic cartridge cleaning by air pulse*
- *Interior or exterior installations*
- *Pleated cartridges for multiple applications*



Superior technology generating substantial operating savings

MAXFLO™

Horizontal high efficiency cartridge collector

MAXFLO *Horizontal high efficiency cartridge collector*

Dust collectors have developed through the past years with emerging technologies. D.A.S. has chosen the best new available components and integrated them in the MAXFLO horizontal cartridge collector. Available in various sizes and configurations, the MAXFLO collector is mostly used to filter fumes created by welding processes, plasma metal cutting or any fine dust resulting from grinding or sanding applications. The electronic control panel ensures interval pulses of air for cleaning the cartridges properly. Safety features such as explosion relief vents, back draft dampers or any other NFPA requirements are available. Also, different dust storage systems are offered ranging from low profile dust drawers for welding applications to multiple drums for larger quantities of dust and particles.

Industrial Air Specialists

With our headquarters in Louisville, Kentucky, Diversified Air Systems, Inc. has been providing quality air solutions to industrial and commercial facilities since 1981. During our more than thirty years of operation, Diversified Air Systems, Inc. has established two important company traditions: offering state-of-the-art equipment at competitive prices and achieving long-term customer satisfaction.

The staff of Diversified Air Systems, Inc. includes five application engineers, with a combined experience of more than 75 years in the air filtration and HVAC industry. Whether your facility requires an air filtration system for dust, mist, or fumes, or an HVAC solution to meet ventilation needs, Diversified Air Systems, Inc. has the equipment and expertise to meet the need.

Services include air quality analysis, system design, equipment sales, turnkey installation, onsite servicing, and supply of replacement filters and accessories.

Other Filtration Systems available:

Air Cleaners

Containment Booths

Decontamination Booths

Downdraft Tables

Dust Collectors

Fans and Blowers

Gas & Odor Control

High Vacuum Systems

Mist Collectors

Paint Booths

Stainless Steel Collectors

Vehicle Exhaust Systems

Wet Dust Collectors



MAXFLO DOWNFLOW CARTRIDGE TYPE DUST COLLECTOR

Most of our competitors do not include these standard features :

- Heavy duty cartridge support yokes
- Multiple dust storage configurations
- Wide selection of Inlet / outlet locations
- Hopper and support structure shipped fully assembled
- Minimal field assembly required
- Welded / bolted cabinet pour les construction

TYPICAL APPLICATIONS FOR THE MAXFLO

- Welding shops
- Training centers and vocational schools
- Grinding, sanding or buffing applications
- General ambient air filtration
- Metal transforming facilities
- Food / pharmaceutical plants



D2MCH4-16 model with low profile 20" dust storage drawer. Also available with 10" version.



D2MCH3-12 model with NFPA explosion vent door and quick dumping bin system.



MAXFLO collector with abrasive resistant inlet for use in applications such as sandblast rooms.



MAXFLO collector with top mounted direct drive fan

OUTSTANDING MAXFLO FEATURES

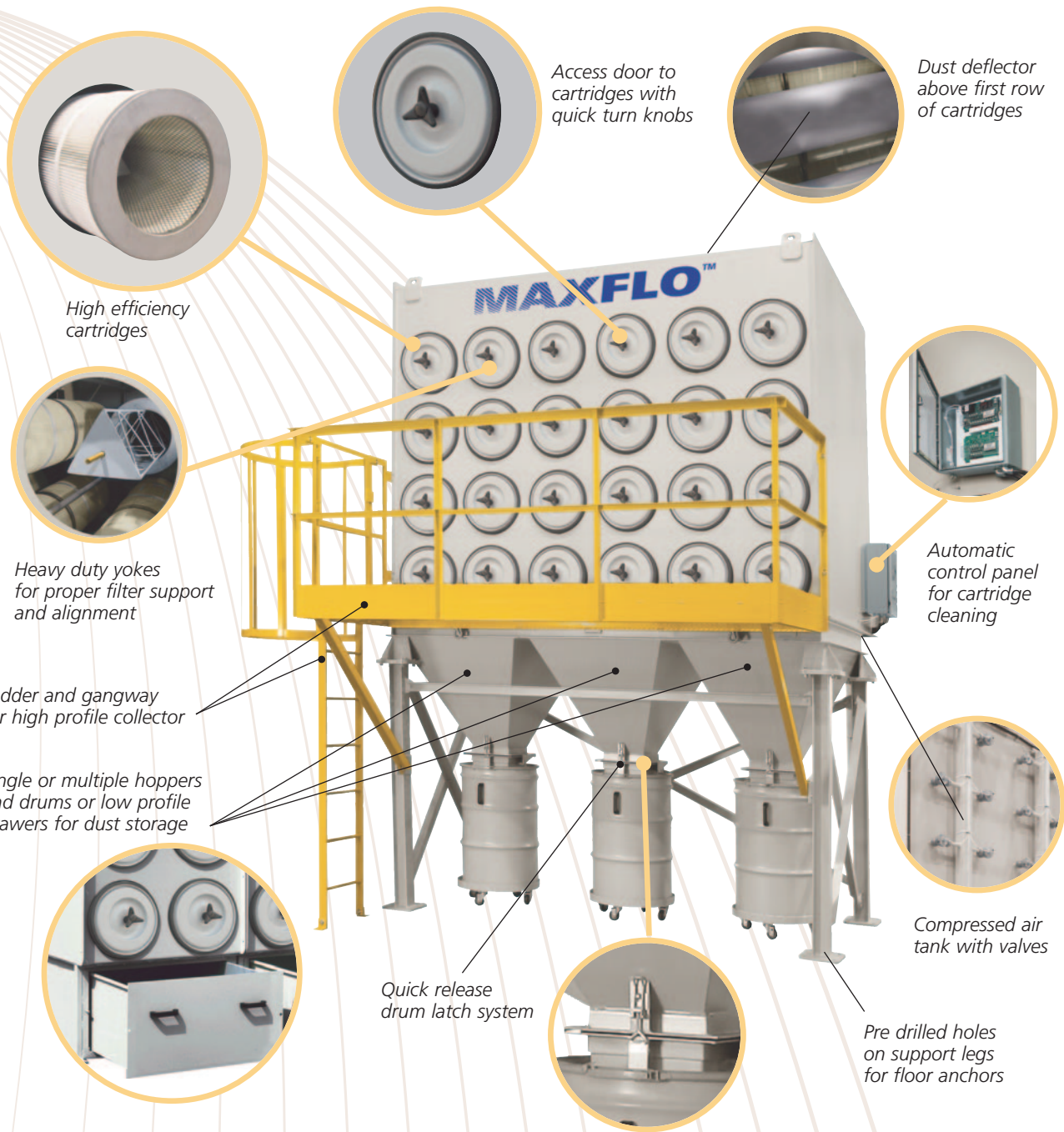

High efficiency cartridges

Access door to cartridges with quick turn knobs

Dust deflector above first row of cartridges

Heavy duty yokes for proper filter support and alignment

Automatic control panel for cartridge cleaning

Ladder and gangway for high profile collector

Single or multiple hoppers and drums or low profile drawers for dust storage

Compressed air tank with valves

Quick release drum latch system

Pre drilled holes on support legs for floor anchors

GENERAL DESCRIPTION

The MAXFLO dust collector is a horizontal down flow type dust collector. Dust-laden air is drawn into the collector by means of a fan. Particles swirl evenly around the horizontally positioned pleated cartridges and are progressively filtered from the outside of the cartridge returning clean air into the facility. Maintenance is greatly reduced since the electronic control panel sends a cascading signal to air valves pulsing compressed air from the inside of the cartridges toward the outside while the unit is in service. This shockwave dislodges dirt and dust from the cartridge surface so it can be collected in the dust storage systems.

MAXFLO SUGGESTED INSTALLATIONS

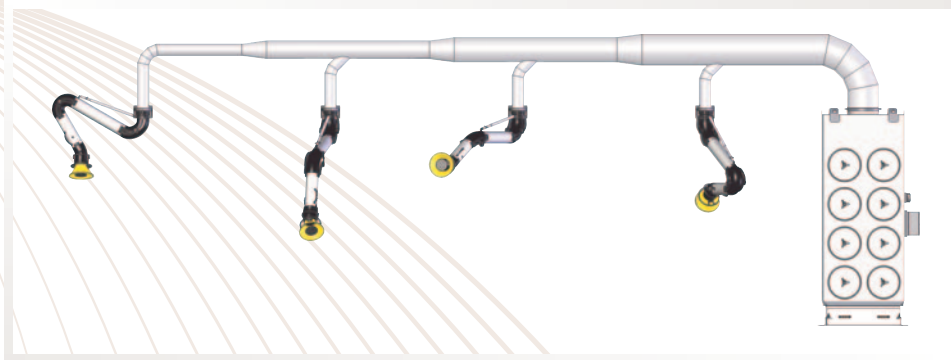

MAXFLO collector with MAXFLO source capture fume arms



MAXFLO collector with MAXDRAFT backdraft welding booths

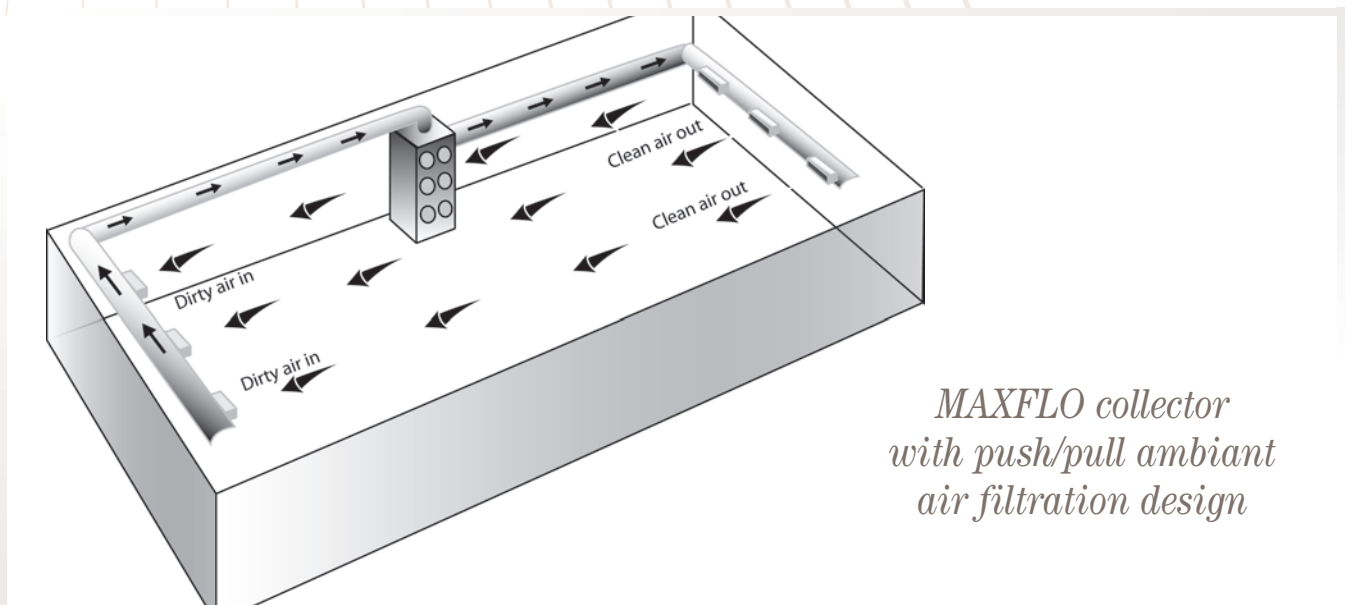

MAXFLO collector with push/pull ambient air filtration design

MAXFLO MODEL NUMBERS AND DIMENSIONS

The two (2) models shown below are single horizontal cartridge deep only

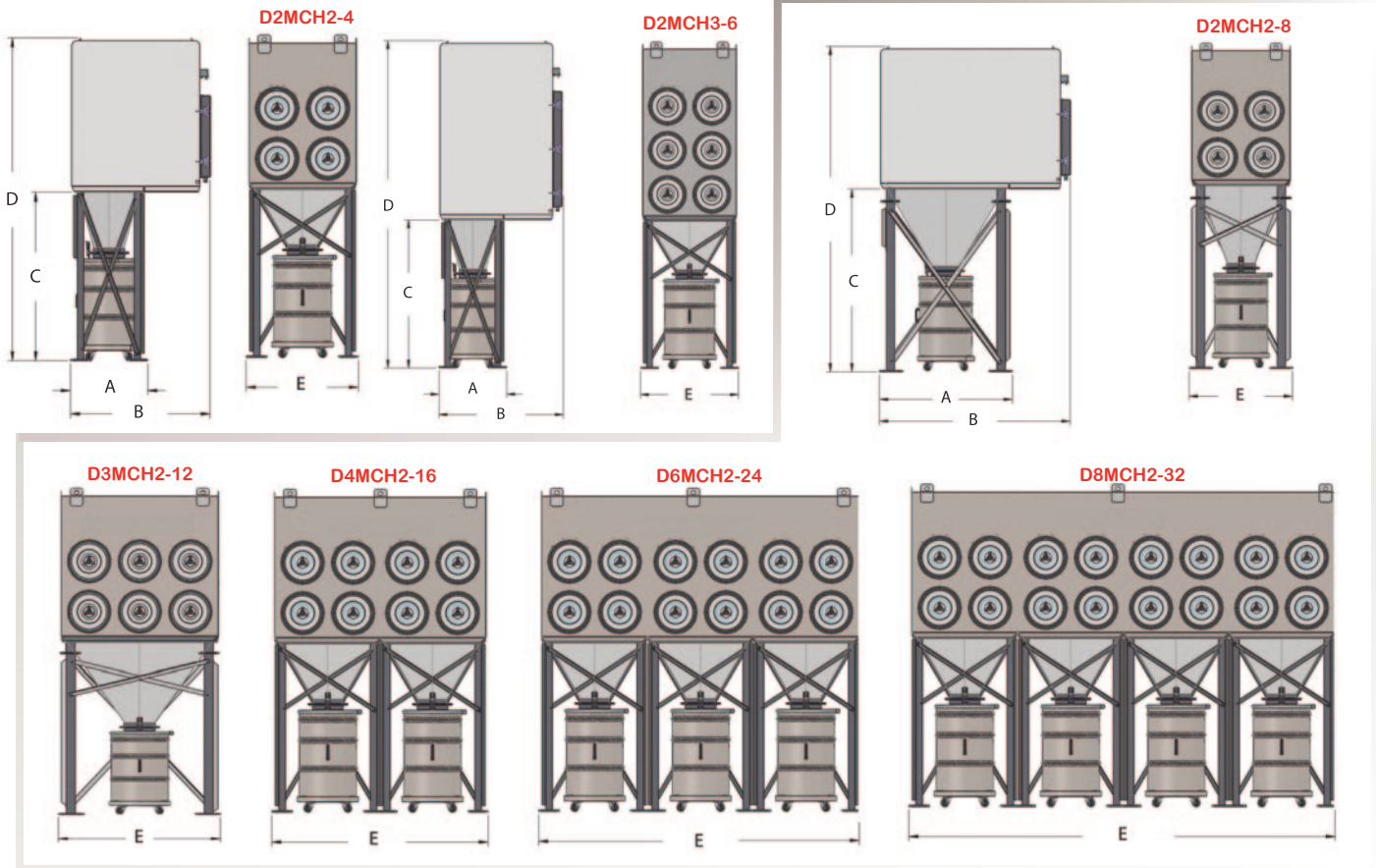

Note: dimensions and weights indicated below do not include optional equipment such as explosion relief vents, fans, control panels, etc.

MAXFLO horizontal cartridge dust collectors use the following method for their model numbers : first digit indicate the number of cartridge access doors in horizontal position. The following three (3) letters "MCH" indicate Modular Cartridge Horizontal. Second digit indicate the number of cartridge access doors in vertical position. Last digit(s) indicate number of cartridges.

CHART 1

Model	Dimensions [inches] / [mm]					Number of cartridges	Filtration surface (Cellulosic/ cartridges) sq.ft./sq.m.	Filtration surface (Cellulosic/ nanofiber cartridges) sq.ft./sq.m.	Filtration surface (Polyester cartridges) sq.ft./sq.m.	Weight lb/kg	Number of valves	Air volume CFM /Ls
	A	B	C	D	E							
D2MCH2-4	30	56	67	128	44	4	1040/96	880/80	520/48	1100/500	4	1000/2500 470/1180
D3MCH2-6						6	1560/144	1320/120	780/72	1300/590	6	1500/4000 710/1890
D2MCH2-8	57	82	78	128	44	8	2080/192	1760/160	1040/96	1500/680	4	2000/5000 945/2360
D3MCH2-12			84	139	64	12	3120/288	2640/240	1560/144	2450/1115	6	3000/7500 1416/3540
D4MCH2-16			91	145	84	16	4160/384	3520/320	2080/192	3000/1365	8	4000/10000 1890/4720
D6MCH2-24	62	85	78	139	104	24	6240/576	5280/480	3120/288	3900/1770	12	6000/15000 2832/7080
D8MCH2-32	62	85	78	139	144	32	8320/768	7040/640	4160/384	5800/2635	16	8000/20000 3775/9440

MAXFLO MODEL NUMBERS AND DIMENSIONS

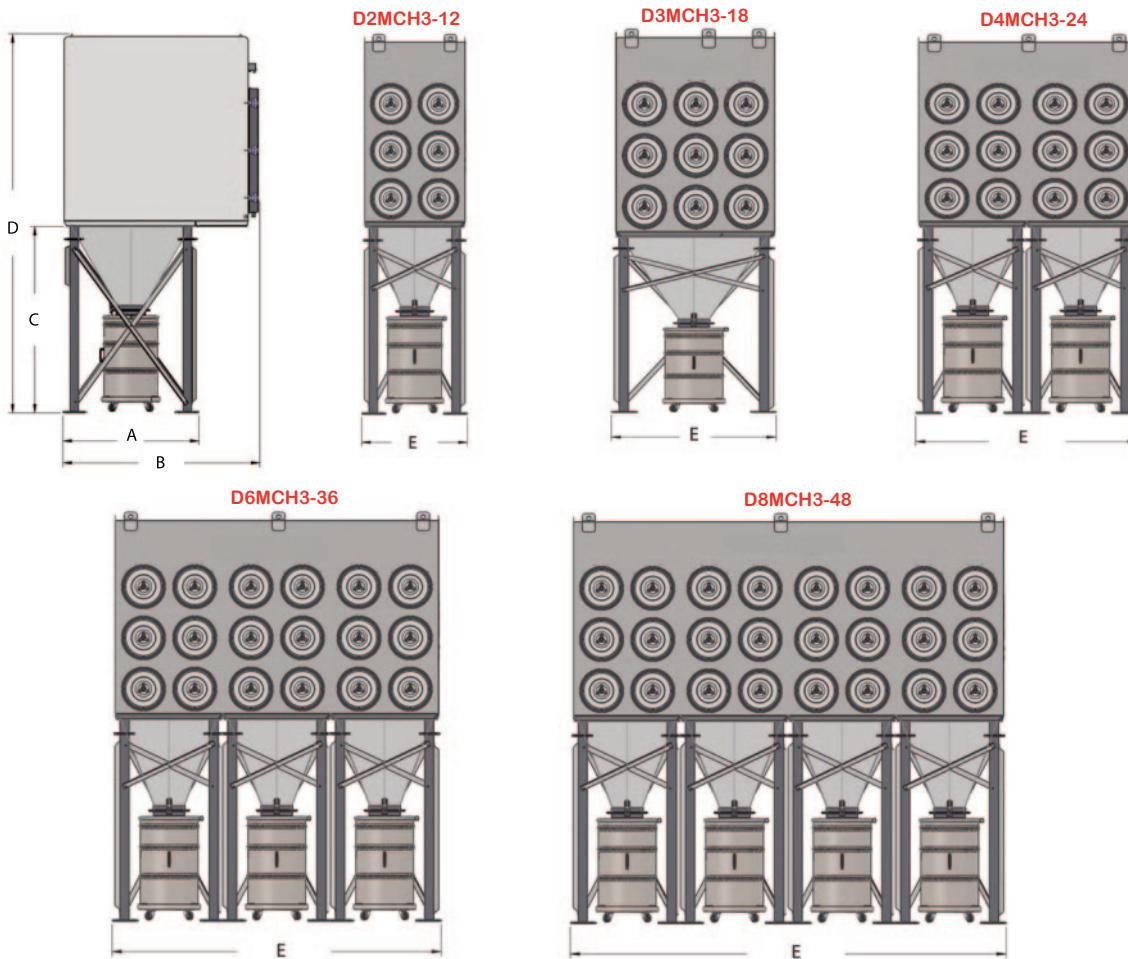

Note: dimensions and weights indicated below do not include optional equipment such as explosion relief vents, fans, control panels, etc.

MAXFLO horizontal cartridge dust collectors use the following method for their model numbers : first digit indicate the number of cartridge access doors in horizontal position. The following three (3) letters "MCH" indicate Modular Cartridge Horizontal. Second digit indicate the number of cartridge access doors in vertical position. Last digit(s) indicate number of cartridges.

CHART 2

Model	Dimensions [inches] / [mm]					Number of cartridges	Filtration surface (Cellulosic/ cartridges) sq.ft./sq.m.	Filtration surface (Cellulosic/ nanofiber cartridges) sq.ft./sq.m.	Filtration surface (Polyester cartridges) sq.ft./sq.m.	Weight lb/kg	Number of valves	Air volume CFM /Ls
	A	B	C	D	E							
D2MCH3-12	57	82	78	159	44	12	3120/288	2640/240	1560/144	2600/1180	6	3000/7000 1416/3300
D3MCH3-18			84	165	64	18	4680/432	3960/360	2340/216	3250/1480	9	4500/10000 2120/4720
D4MCH3-24			91	172	84	24	6240/576	5280/480	3120/288	4100/1860	12	6000/15000 2830/7080
D6MCH3-36	62	85	78	159	124	36	9360/864	7920/720	4680/432	6400/2910	18	9000/20000 4250/9440
D8MCH3-48	62	85	78	159	164	48	12480/1152	10560/960	6240/576	8200/3730	24	12000/30000 5660/14160

MAXFLO MODEL NUMBERS AND DIMENSIONS

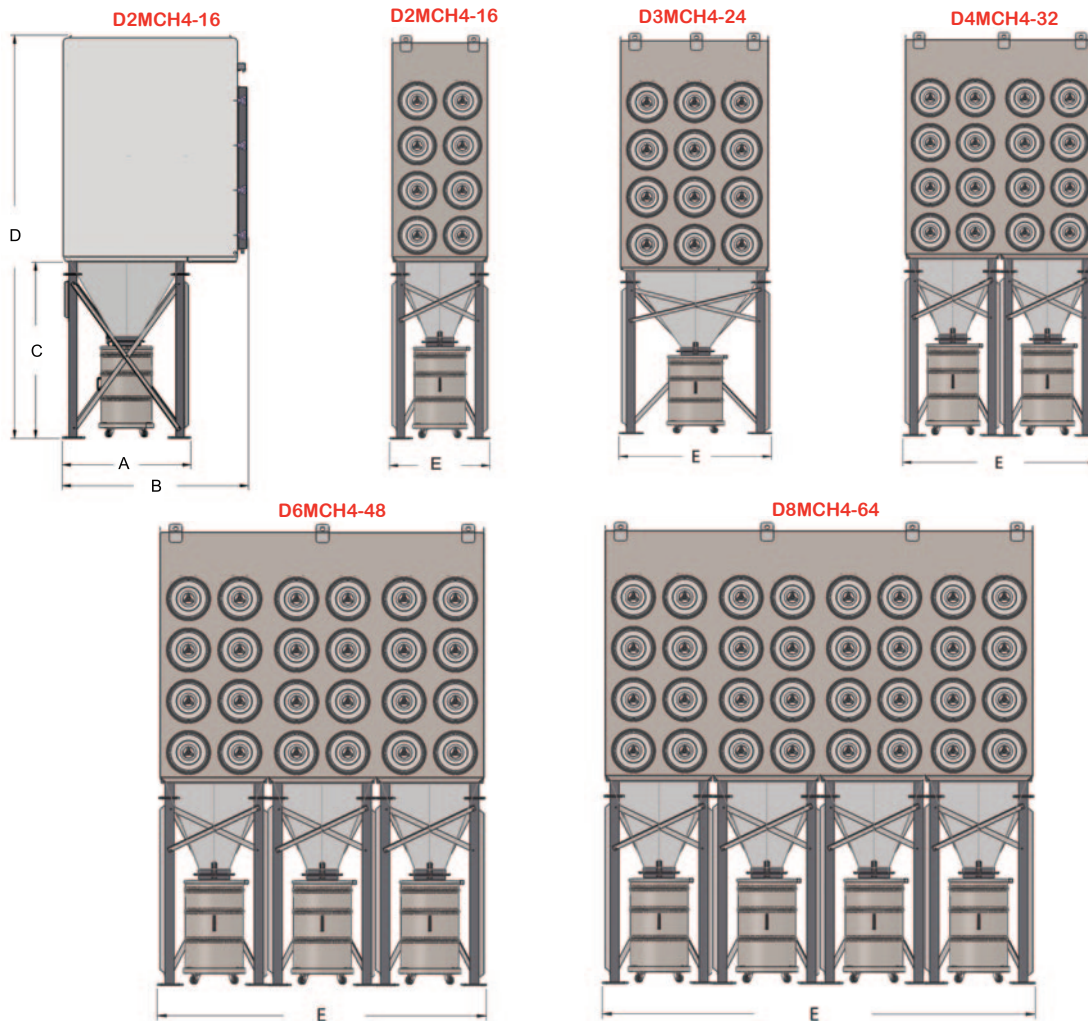

Note: dimensions and weights indicated below do not include optional equipment such as explosion relief vents, fans, control panels, etc.

MAXFLO horizontal cartridge dust collectors use the following method for their model numbers : first digit indicate the number of cartridge access doors in horizontal position. The following three (3) letters "MCH" indicate Modular Cartridge Horizontal. Second digit indicate the number of cartridge access doors in vertical position. Last digit(s) indicate number of cartridges.

CHART 3

Model	Dimensions [inches] / [mm]					Number of cartridges	Filtration surface (Cellulosic/ cartridges) sq.ft./sq.m.	Filtration surface (Cellulosic/ nanofiber cartridges) sq.ft./sq.m.	Filtration surface (Polyester cartridges) sq.ft./sq.m.	Weight lb/kg	Number of valves	Air volume CFM /Ls
	A	B	C	D	E							
D2MCH4-16			78	179	44	16	4160/384	3520/320	2080/192	3100/1410	8	4000/10000 1890/4720
D3MCH4-24	57	82	85	185	64	24	6240/576	5280/480	3120/288	4100/1865	12	6000/15000 2830/7080
D4MCH4-32			91	192	84	32	8320/768	7040/640	4160/384	6000/2730	16	8000/20000 3775/9440
D6MCH4-48	62	85	78	179	124	48	12480/1152	10560/960	6240/576	8400/3820	24	12000/30000 5660/14160
D8MCH4-64	62	85	78	179	164	64	16640/1536	14080/1280	8320/768	10800/4910	32	16000/40000 7550/78880

PRINCIPLE OF OPERATION

During operation, dusty air ① enters the collector from the top and takes a down flow air pattern ②. Dust and smoke are filtered as they penetrate into the cartridge fabric ③ and is vacuumed into the clean air plenum ④.

An electronic control panel sends multiple signals at different intervals to the diaphragm valves ⑤ which release a small amount of compressed air from the tank ⑥ into the venturi cones ⑦. The shockwave ⑧ created by the acceleration of the compressed air pushes the contaminants away from the cartridge fabric ⑨. Gravitational effect takes over and the contaminants continue downward to the hopper and dust storage system ⑩.

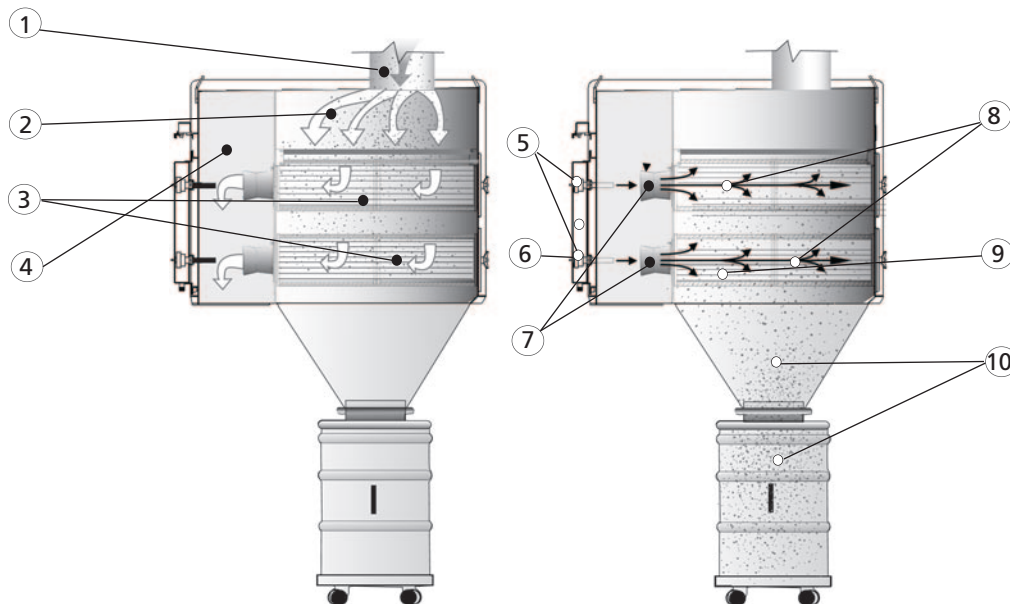

COMPRESSED AIR CLEANING INFORMATION

MAXFLO dust collectors uses approximately 8 to 12 SCFM per pulse. Recommended compressed air pressure for proper cartridge cleaning: 90 p.s.i.

Air line feeding the MAXFLO collector should be equipped with a filter, regulator and dryer for longer life expectancy of valves.

MAXFLO collectors installed outside in cold climates should be equipped with a solenoid heating element.

Standard panel includes programmable timer to pulse at intervals of 1 to 180 seconds. Optional panel includes Differential Pressure Controller (DPC) regulating air pulses by pressure sensors or manually programmed from 1 to 255 seconds.

RECOMMENDED DUCT VELOCITIES FOR PARTICULATES

CHART 4

Type of dust	F.P.M. /meter per second
Welding smoke	2500 / 12
Flour type dust	3800/19
Metal dust	4200 / 21
Heavy metal dust	5000 / 25

Note: other particle velocities may be required. Refer to Industrial Ventilation Handbook for more details or contact DAS.
 Note: installation must be made according to local building codes and regulations.

APPLICATIONS

The MAXFLO is an enclosure type dust collector. MAXFLO dust collectors can be used with different dusts such as welding smoke, metal sanding, grinding or buffing, plasma/laser downdraft cutting tables, sandblast rooms operation, light to medium sized dry powders, food and pharmaceutical plants or plastic and composites fabricating shops.

SAFETY RULES AND REQUIREMENTS

Reactive metals application

The National Fire Protection Agency (NFPA) standard 484 defines aluminum, magnesium, tantalum, titanium and zirconium as reactive metals so it is imperative that NFPA 484 standard be observed at all times and that the collector be installed outside of the facility or premises with all required safety devices. Reactive metals listed above shall not be mixed in the same MAXFLO collector. Individual dust collectors shall be used for each reactive dust.

The MAXFLO dust collector should include a sign indicating **CAUTION** when used with explosive dusts.

The MAXFLO dust collector should include a sign indicating **WARNING** when used with aluminum dusts advising danger of mixing with other dusts.

SHIPPING

In order to facilitate shipping and installation, DAS usually ships the hopper and support structure fully assembled ready for cabinet mount. Larger MCH models may require more extensive field assembly.

Optional equipment such as dampers or silencers are shipped separate and require field assembly. Explosion venting doors are factory installed on the dust collector cabinet.

MAXFLO CARTRIDGE SELECTION

CHART 5

MEDIA	FILTRATION SURFACE Sq. ft./Sq. m.	APPLICATION	EFFECIENCY
Cellulose	260 / 24	Smoke, fumes, non fibrus dust, fine dust (light concentration)	0.3 to 1µ : 85.1% 1.0 to 3.0 µ : 96.1% 3.0 to 10.0 µ : 99.4%
Polyester	130 / 12	Smoke, fumes, fibrus dust, fine dust (medium concentration)	90 to 99.93% @ 0.2 to 2.0 µ
Nanofiber	220 / 20	Smoke, fumes, non fibrus dust, fine dust (light concentration)	0.5 µ : 99.8% 1.0 µ : 99.9% 2.0 µ : 99.999%
Fire retardant	260 / 24	Smoke, fumes, non fibrus dust, fine dust (light concentration)	0.3 to 1µ : 85.1% 1.0 to 3.0 µ : 96.1% 3.0 to 10.0 µ : 99.4%
Antistatic	130 / 12	Smoke, fumes, fibrus dust, fine dust (medium concentration)	0.3 to 1µ : 85.1% 1.0 to 3.0 µ : 96.1% 3.0 to 10.0 µ : 99.4%

Maximum operating temperature: 120 to 180 deg. F. (50 to 80 deg. C.)

Other filter media available such as teflon coated cartridges or high heat usage. Contact DAS or representative for details.

Note : MAXFLO maximum air volume capacity is rated as per cartridge filtration surface. For best results and longer cartridge life expectancy, air to cloth (filtration surface) should not exceed 3 to 1 for collectors used for ambient air filtration and 2 to 1 with source capture equipment (fume arms or equivalent).

Ex : MAXFLO collector D4MCH2-16 fitted with MAXFLO fume arms and 260 sq. ft. cartridges = 4160 sq. ft. X 2 (air to cloth) = 9320 C.F.M

OPTIONAL ACCESSORIES AND DESCRIPTION

Explosion venting doors



Requirement by NFPA for reactive material such as wood dusts and chips, aluminum and/or magnesium collection.

Fan outlet silencers



Sound attenuators for high velocity discharge of air.

Tamper proof bars



Safety device preventing unauthorized access to cartridges.

Rotary airlock

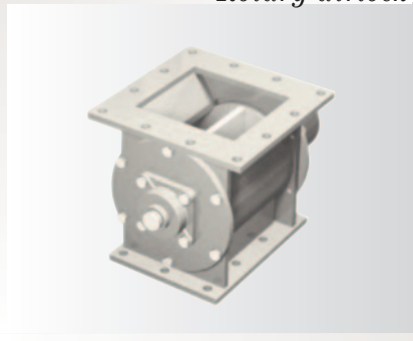

Rotary airlock for constant dust discharge.

Slide / blast gates



Used for shutting off air vacuum on specific equipment.

Blowback dampers

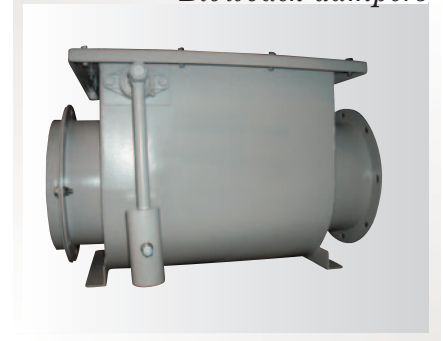

Safety device preventing flames or explosion in dust collector from coming back into the building.

Spark detection/extinguishing systems



Recommended safety device for highly abrasive metal or wood transforming applications.

Sprinklers



Safety device to extinguish possible fires in dust collectors.

Abort dampers



Safety device preventing a possible explosion in a dust collector from coming back into the building and exhausting pressure in the atmosphere.

Safety device and equipment notes : design built and/or engineered dust collecting equipment may require different safety devices as described above. Refer to NFPA rules and regulations for appropriate devices. DAS or it's representative may also guide you in proper selection of equipment as per the application.

It is highly recommended to refer to local building laws and safety requirements prior to selecting or installing any type of dust collecting equipment.

Installation note : it is recommended to allow 36" (0.9 meter) work and access space around the collector for installation and possible maintenance.

CREATE YOUR MAXFLO FILTRATION UNIT SPECIFICATION

1. UNIT SHOULD INCLUDE:

10 and 14 gauge polyurethane painted with epoxy, aluminum primer steel cabinet, high efficiency pleated cartridge(s) with gasketed access doors and turn knobs, air venturis for proper pulse cleaning action on cartridges, heavy duty support yokes for cartridges, dust deflectors above first row of cartridges, magnehelic pressure gauge, dust hopper and dust storage drums with grab handle, flexible hose connection from hopper to dust bin, electronic control panel with adjustable timer for pulse cleaning in NEMA 4 enclosure, 1" NPT compressed air connection to air tank, diaphragm valves with solenoids, cabinet lift lugs, painted steel support structure with cross braces and pre-drilled holes for floor anchoring, seismic rating zone 4.

2. MODEL TO BE:

D___MCH___-___ (Ex: D2MCH3-12)

3. CARTRIDGES TO BE:

- A) cellulose (260 sq. ft. each)
- B) fire retardant cellulose (260 sq. ft. each)
- C) nanofiber (260 sq. ft. each)
- D) polyester(130 sq. ft. each)
- E) anti-static polyester(130 sq. ft. each)
- F) tandem polyester with evenly spaced V pleats (130 sq. ft. each)

4. FAN PERFORMANCE TO BE :

___ CFM@ ___" S.P. (Ex: 5000 CFM@ 6"S.P.)

___ L/s@ ___pa S.P. (Ex: 2360 L/s @ 1500 pa S.P.)

5. DRUM DUST STORAGE UNIT SHOULD BE SUBSTITUTED FOR:

- A) 10 " high dust drawers
- B) 20" high dust drawers
- C) quick dumping bin system

6. DIRTY AIR INLET SHOULD BE LOCATED AT :

- A) top of dust collector
- B) front of dust collector

7. CLEAN AIR OUTLET SHOULD BE LOCATED AT :

- A) top rear of dust collector
- B) bottom rear of dust collector
- C) left rear of dust collector
- D) right rear of dust collector

8. UNIT TO BE EQUIPPED WITH :

- A) NFPA explosion relief vent
- B) sprinkler head
- C) abort damper
- D) blowback damper
- E) spark detection/extinguishing system
- F) cartridge access doors tamper proof bars
- G) rotary airlock
- H) slide gate at drum/hopper connection
- I) differential pressure controller for automatic pulse cleaning
- J) fan outlet silencer
- K) safety after-filter cabinet with primary 30% pleated filters and secondary 85% polyester bag filters
- L) support structure and hopper enclosure with access door
- M) access ladder and service platform for high profile dust collectors
- N) bag in / bag out cartridge replacement
- O) drum dollies with casters
- P) drum covers

9. UNIT DESIGNED FOR :

- A) interior installation
- B) exterior installation
- C) exterior installation in cold climate

Note : specifications listed above may be modified to suit application. Contact D.A.S. or representative for information.

Diversified Air Systems, Inc.

10801 Electron Drive, Louisville, Kentucky 40299

Toll free: **(800) 264-8958**

Tel.: **(502) 267-0333** • Fax: **(502) 267-4241**

Website: www.diversair.com • email: info@diversair.com

Continuous product improvement is a policy of D.A.S. Inc. Product features and specifications may be modified without prior notice.