

DIVERSIFIED AIR SYSTEMS, INC.

# MAXFLO-MC™

*Stand alone pleated  
cartridge dust collector*

- *Plug and play type unit*
- *High efficiency cartridge*
- *Ideal for welding, light grinding and general dust applications*



- *Complete automatic pulse cleaning system*
- *1,2 or 3 cartridges configuration*
- *Air volume from 600 to 2200 CFM*

*Superior technology generating substantial operating savings*

# MAXFLO-MC™

*Stand alone dust collector*

## **MAXFLO-MC** *Stand alone high efficiency cartridge collector*

MAXFLO-MC cartridge collectors are designed for a wide range of particle filtration. Using the same technology as the regular and larger MAXFLO units, the MAXFLO-MC has the advantage of being installed quickly and easily. Shipped fully assembled and taking very little footprint, the unit can be in service rapidly. The quiet motor-fan assembly with anti-spark polyamide backward inclined impeller allows great air volume and medium to high static pressures. The integrated control panel ensures constant and reliable cleaning of the cartridges by air pulse. Efficiency of cartridges may allow recirculation of filtered air into the premises (some restrictions apply).

Maintenance is a snap by only emptying the dust storage bin. Safety features such as NFPA explosion relief venting doors or sprinklers may be added to the unit.

## *Industrial Air Specialists*

With our headquarters in Louisville, Kentucky, Diversified Air Systems, Inc. has been providing quality air solutions to industrial and commercial facilities since 1981. During our more than thirty years of operation, Diversified Air Systems, Inc. has established two important company traditions: offering state-of-the-art equipment at competitive prices and achieving long-term customer satisfaction.

The staff of Diversified Air Systems, Inc. includes five application engineers, with a combined experience of more than 75 years in the air filtration and HVAC industry. Whether your facility requires an air filtration system for dust, mist, or fumes, or an HVAC solution to meet ventilation needs, Diversified Air Systems, Inc. has the equipment and expertise to meet the need.

Services include air quality analysis, system design, equipment sales, turnkey installation, onsite servicing, and supply of replacement filters and accessories.

### **Other Filtration Systems available:**

Air Cleaners

Containment Booths

Decontamination Booths

Downdraft Tables

Dust Collectors

Fans and Blowers

Gas & Odor Control

High Vacuum Systems

Mist Collectors

Paint Booths

Stainless Steel Collectors

Vehicle Exhaust Systems

Wet Dust Collectors



## MAXFLO-MC DOWNFLOW HORIZONTAL CARTRIDGE COLLECTORS

- Ideal for welding fumes and fine grinding dusts
- Self cleaning with automatic reverse air pulse
- Minimal footprint
- Compact dust storage bin
- Robust painted steel cabinet
- Plug and play type unit

## OUTSTANDING MAXFLO-MC FEATURES

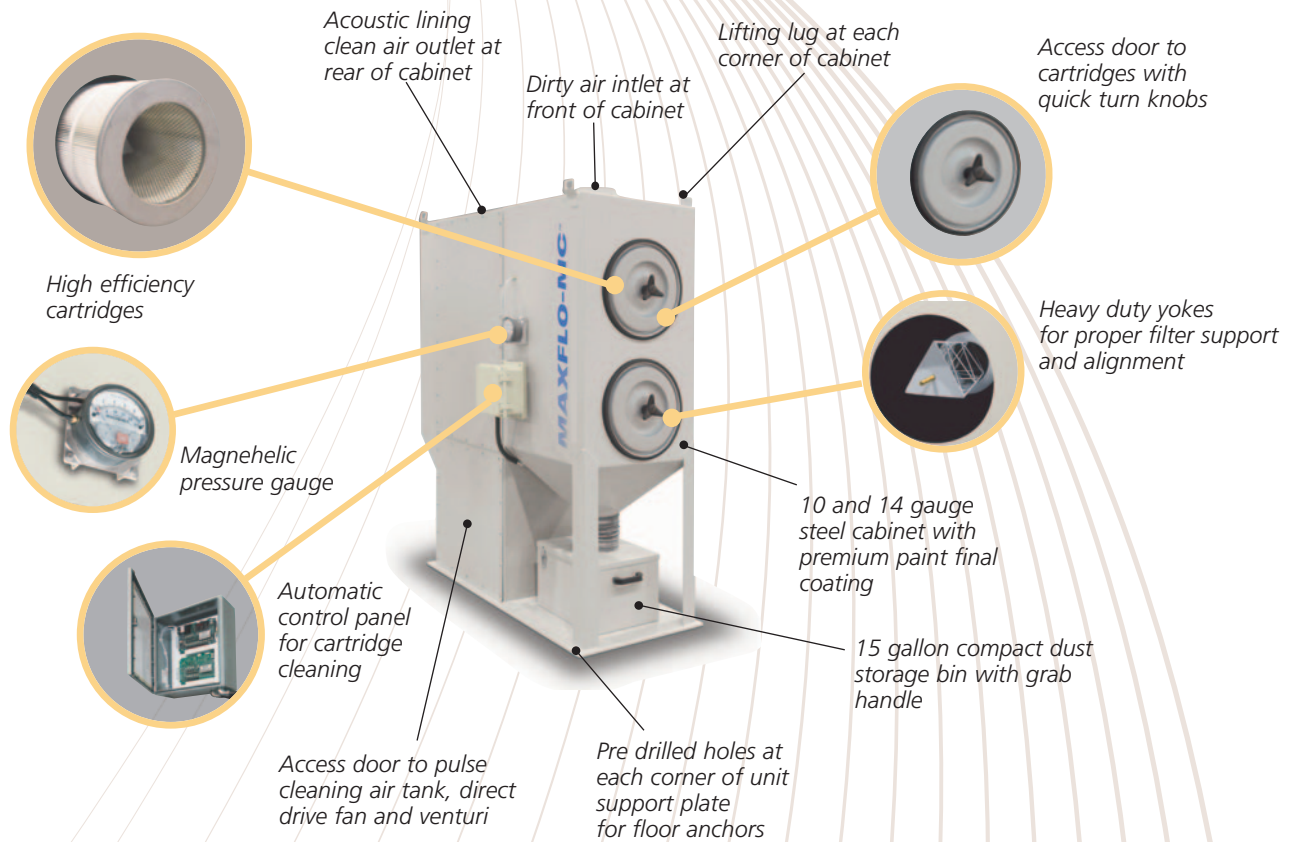

## GENERAL INFORMATION

CHART 1

MODEL	# OF CARTRIDGES	FILTRATION SURFACE SQ.FT. / SQ.MT	MAX. AIR VOLUME CFM / LS	MAX. HP / KW	MOTOR RPM	WEIGHT LB / KG	AIR PRESSURE REQUIRED (PULSE CLEANING)
DDMC-01	1	260 / 24	600 / 285	1.50 / 1.10	1750 / 3500 (as per static pressure required)	870 / 370	60-80 PSI
DDMC-02	2	520 / 48	1450 / 685	1.5-2.00 / 1.10-1.5		1080 / 490	
DDMC-03	3	780 / 72	2200 / 1040	3.00-5.00 / 2.25-3.75		1210 / 550	

Motor voltages note: Fan motors are available in all standard voltages. Contact your representative for specifications.

### Cartridge efficiency:

130 sq. ft. polyester: U.S. & G 99.93 @ 0.2/2.0 microns

130 sq. ft. polyester anti-static: U.S. & G 99.93 @ 0.2/2.0 microns

130 sq. ft. polyester tandem: U.S. & G 99.93 @ 0.2/2.0 microns (40% more dust holding capacity)

260 sq. ft. regular cellulose: U.S. & G 99.5 @ 0.2/2.0 microns

260 sq. ft. nanofiber: MERV 15 as ASHRAE 52.2

260 sq. ft. fire retardant: U.S. & G 99.5 or MERV 15

Note: Installation must be made according to local building codes and regulations.

**DIMENSIONS**

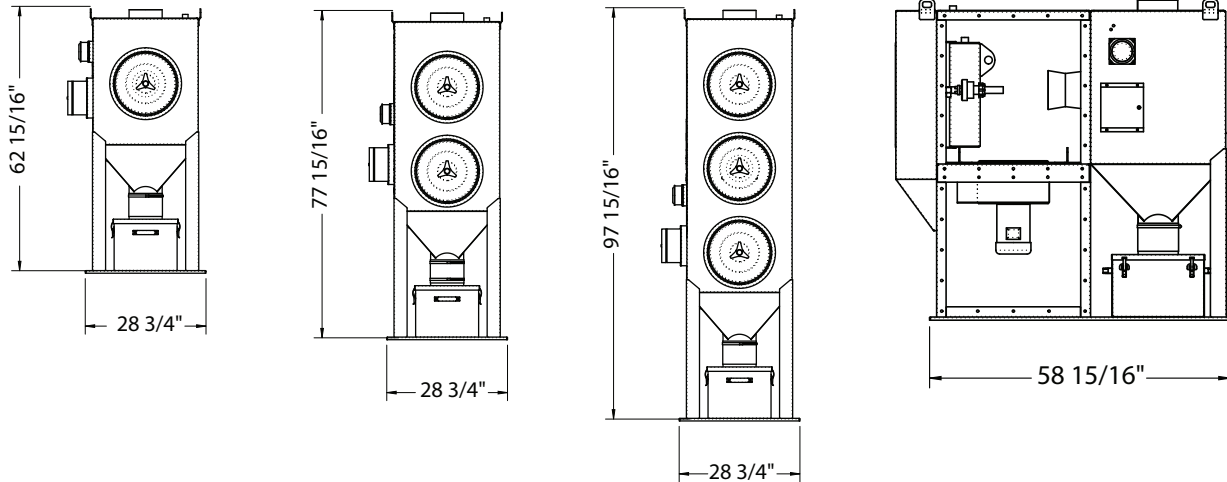

**CREATE YOUR MAXFLO-MC FILTRATION UNIT SPECIFICATION**

**1. UNIT SHOULD INCLUDE:**

10 and 14 gauge epoxy painted with primer steel cabinet, high efficiency cartridges, access doors to cartridges, heavy duty support yokes for cartridges, venturis for proper cartridge pulse cleaning, dust deflector above first cartridge, magnehelic gauge, dust hopper and dust storage bin with grab handle, flexible hose connection from hopper to dust bin, electronic control panel with adjustable timer for pulse cleaning in NEMA 4 enclosure, TEFC motor with acoustical plenum, 1" NPT compressed air connection, top inlet and outlet lift lugs, painted steel support structure with pre-drilled holes for floor anchoring seismic zone 4, bolted access door to direct drive fan/motor assembly, anti-spark polyamide backward inclined impeller.

**2. MODEL TO BE:**

- A) DDMC-01 (260 sq. ft. of filtration surface)
- B) DDMC-02 (520 sq. ft. of filtration surface)
- C) DDMC-03 (780 sq. ft. of filtration surface)

**3. VOLTAGE TO BE:**

- 115/1 /60
- 230/1 /60

- 208/3 /60
- 460/3/60
- 575/3/60

**4. STANDARD CELLULOSE CARTRIDGES TO BE SUBSTITUTED FOR:**

- A) Fire retardant cellulose cartridges (260 sq. ft. each)
- B) Nanofiber cartridges (260 sq. ft. each)
- C) Polyester cartridges (130 sq. ft. each)
- D) Anti-static Polyester cartridges (130 sq. ft. each)
- E) Tandem polyester cartridges with evenly spaced V pleats (130 sq. ft. each)

**5. UNIT TO BE EQUIPPED WITH:**

- A) NFPA explosion relief vent
- B) Sprinkler head
- C) Magnetic starter with overload protection
- D) 4" swivel casters with foot brake

**6. STANDARD ADJUSTABLE TIMER FOR CARTRIDGE CLEANING TO BE SUBSTITUTED FOR:**

- Differential static pressure controller

**Diversified Air Systems, Inc.**

10801 Electron Drive, Louisville, Kentucky 40299

Toll free: **(800) 264-8958**

Tel.: **(502) 267-0333** • Fax: **(502) 267-4241**

Website: [www.diversair.com](http://www.diversair.com) • email: [info@diversair.com](mailto:info@diversair.com)

Continuous product improvement is a policy of D.A.S. Inc. Product features and specifications may be modified without prior notice.